

LANDSHARK EVAPORATOR

WASTE WATER EVAPORATION SYSTEM



The LANDSHARK EVAPORATOR is designed for use in large evaporation ponds or areas where over spray is less of a concern. The fan's airflow produces a large spray pattern which allows longer float times of the spray in the air, thus allowing greater evaporation rates.

(Evaporation rates will depend greatly on weather conditions such as ambient temperatures, relative humidity, wind speed, etc).

The LANDSHARK EVAPORATOR comes with its own 15hp centrifugal pump package incorporating 2" reinforced suction hose with float and foot valve and 2" reinforced discharge hose. A PLC controlled automatic weather station is also offered as an option. The weather station allows site programming of wind speed and direction to automatically start-up and shut down the pump, when applicable, at preset wind speeds and directions.

FEATURES

- Fan's airflow in excess of 100 mph
- 3 wheel, trailer, float mounted or skid mounted
- Oil field duty construction
- New rubberized powder coating for better protection
- 360 degree directional rotation
- PLC controlled automated wind speed & direction control system available
- Pump packages available
- 2" Stainless steel manifold with 30 spiral jet nozzles
- Flow rate up to 110 gpm

TRAILER MOUNTED



SKID MOUNTED



3 WHEEL MOUNTED



FLOAT MOUNTED



TECHNICAL SPECIFICATIONS

ITEM	SPECIFICATION
Power Source	460V 60/50Hz
Material makeup of unit	Barrel: carbon steel/powder coated Spray ring: 316 stainless steel Three wheeled cart: carbon steel/rhino lined or powder coated
Fan power	17.5kW / 25hp
Pump power	10.5kW / 15hp
Pump rate	416 lpm / 110 gpm
Minimum water operating depth	457mm / 18in
Water plume	45.7m / 150 Ft
Platform	Skid mounted or three wheel cart
Recommended pond size	106m x 47.2m / 350ft x 150ft

WEIGHTS AND DIMENSIONS

ITEM	SPECIFICATION
Skid mounted dimensions	2.14m L x 1.23m W x 1.83m H 7ft L x 4.25ft W x 6ft H
Skid mounted weight	635kg / 1400lbs
Pump unit dimensions	1.12m L x 0.4m W x 0.69m H 3.75ft L x 1.33ft W x 2.25ft H
Pump unit weight	181.5kg / 400lbs

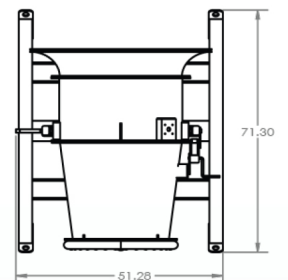
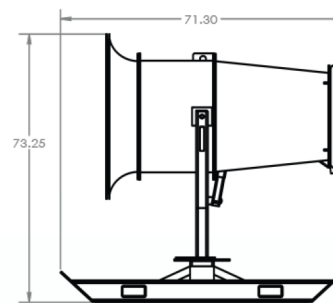

New Cairo, Egypt
5th Settlement,
North 90th Street
Villa 238
T: +20225381693
F: +20225381693
info@idecint.com

Dubai, UAE
JLT, Cluster W, Liwa Heights
Office 2301
P.O. Box 31956, Dubai
T: +971 4 4518052
F: +971 4 4518032
info@idecint.com

